

Generation five's

www.h2oneutralizer.com

Model 3M

3100 Series - Gen. 5

# Chlorinate/ DeChlorinate

With More Precise Control than ever  
with Generation Five of

Rated for Flow Range  
of 1 to 1250+gpm\*

\*Partial vacuum created from 3/4 gpm to 10 gpm,  
device reaches full vacuum at 10 gpm and above.

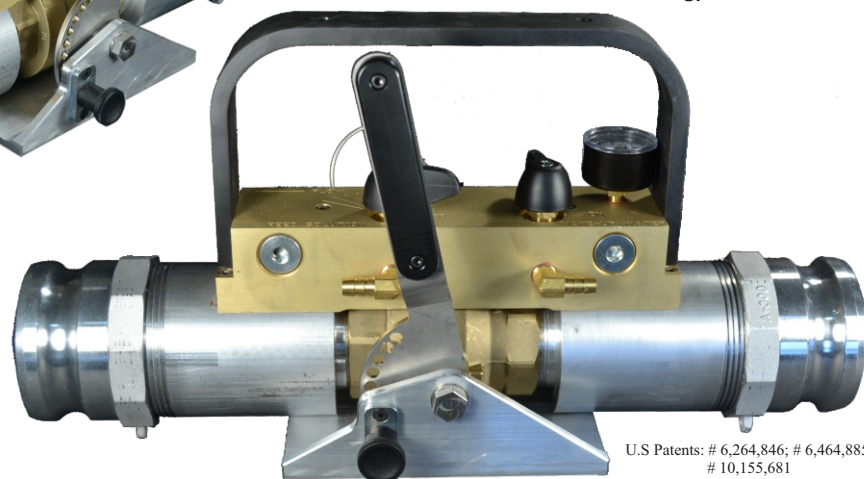

U.S. Patents: # 6,264,846; # 6,464,885;  
# 10,155,681

Four  
Package  
Combinations  
to Choose  
From

Patented Venturi & Locking Ball Valve Design  
Operates on Nothing More than the Flow of Water  
Through the Device

the

# H<sub>2</sub>O Neutralizer<sup>Gen.5</sup>®

Simply <sub>2</sub> the Best Chlorinator/DeChlorinator on the Market Today

The 3M H<sub>2</sub>O Neutralizer (gen.5)'s patented Lateral Bypass Venturi design provides superior performance, achieving full vacuum at flows as low as 10 GPM with consistent solution feed of 1 gallon per minute through its entire rated range of flow. Generation 5 ball valve design provides greater precision flow control down to 1 gpm.

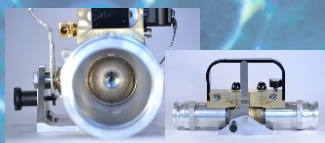

new

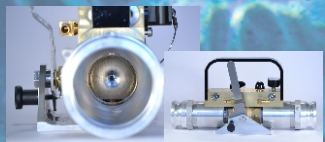

ball valve



design

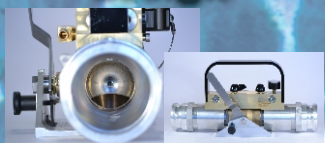

features

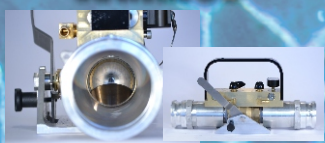

nine separate

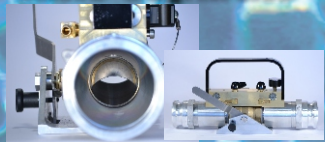

flow settings for

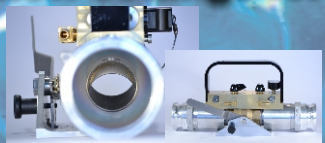

greater precision

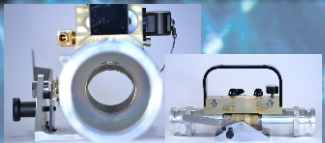

in controlling

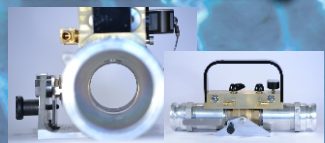

water flow



# Measurement Technologies

# Truly the Most Effective Chlorinator/Dechlorinator Available Anywhere.

With its patented venturi design and ball valve flow control the 3M H<sub>2</sub>O Neutralizer (gen.5) delivers a range of performance no other device on the market today can match.

Able to draw & inject one gallon of chemical per minute at flow rates as low as 9 GPM, the model 3M can handle flow rates over twelve hundred and fifty gallons per minute with consistent chemical injection performance throughout the entire range of flow rates. Flow of chemical can be adjusted from 0 to 1 gpm with chemical flow control valve on the venturi block.

This new design allows you to set your equipment up, start your water flow, adjust for proper vacuum and chemical feed and get the job done. No more disassembling equipment required to change orifice rings if proper flow isn't achieved. Just adjust the ball valve for proper flow and go.



3M-3100 - Gen.5

Available in a variety of packages, there is sure to be combination to meet your project requirements.

Give us a call, or visit us on-line, today to learn more about how the 3M H<sub>2</sub>O Neutralizer (Gen-5) can deliver better performance in your chlorination and dechlorination projects.



Chlorination Kit



Diffuser Kit

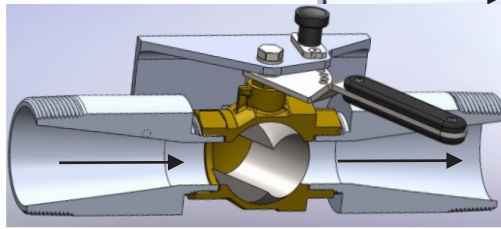

Patented Venuturi design and ball valve flow control give H<sub>2</sub>O Neutralizer an unmatched range of performance.

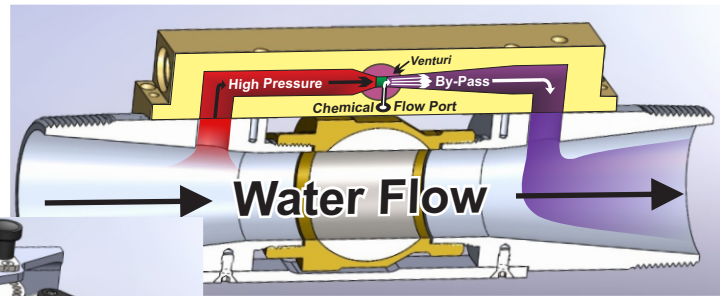

It's patented lateral-by-pass venturi permits the H<sub>2</sub>O Neutralizer to operate with no power...



just the flow of water creates the vacuum needed...

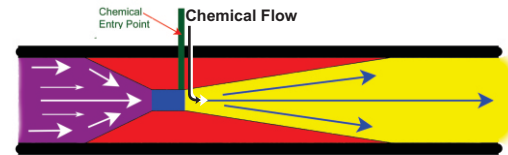

VENTURI DESIGN

to draw in chemical at 1 GPM at flow rates through the device ranging from 10 GPM to over 1300 GPM.

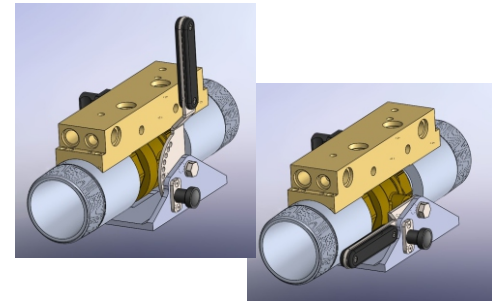

Our new Gen.5 ball-valve design offers nine separate mainline orifice settings for more precise control of water flow while the device is in operation.

## 3M H<sub>2</sub>O Neutralizer(Gen.5) Packages

|  | 3M-3100 | 3M-3105 | 3M-3150 | 3M-3155 |
|--|---------|---------|---------|---------|
| <b>3M H<sub>2</sub>O Neutralizer</b> includes:<br>3M H <sub>2</sub> O Neutralizer (Gen.5) Device & Storage Case,<br>Orifice Ring Insert set (1.5", 1.0", 0.75"),<br>Type "D" Cam Lock Adaptor (2½" FNST x 3"), - 3" Dust Cap -<br>5' - ¾" Tubing (2), - 16oz. No-Chlor™ Calcium thiosulfate Solution | ✓       | ✓       | ✓       | ✓       |
| <b>Chlorination Kit</b> Includes:<br>2" Chlorination Test Port Adaptor,  |         | ✓       |         | ✓       |
| <b>Diffuser Kit</b> includes:<br>3" x 20' Nitrile Rubber Discharge hose,<br>3" Full Flow Diffuser  |         |         | ✓       | ✓       |

# H<sub>2</sub>O Neutralizer<sup>Gen.5</sup>®

Simply the Best Chlorinator/DeChlorinator on the Market Today



# Measurement Technologies

www.h2oneutralizer.com

PO Box 2195, Redmond, WA 98073

Toll Free 877-889-8482